

END-USER
USE AND MAINTENANCE MANUAL

ZIP

SWING GATE AUTOMATION—FOR RESIDENTIAL/COMMUNITIES

D_MNLOZIP 17-11-2015 - Rev.19



IT - Istruzioni originali



MADE IN ITALY



INSTRUCTIONS AND WARNINGS FOR AUTOMATIC SYSTEM USERS

CONGRATULATIONS on choosing a Tau product for your automation system!

Tau S.r.l. produces components for automatic gates, doors, barriers and shutters. These include gear motors, control units, radio control devices, flashing lights, photocells and accessories.

Tau products are exclusively made with top quality materials and processes and, as a company, we constantly research and develop innovative solutions in order to make our equipment increasingly easier to use. We also pay great attention to all details (technology, appearance and ergonomics). The extensive Tau range makes it possible for your fitter to choose the product which best meets your requirements.

Tau, however, does not produce your automated system as this is the outcome of a process of analysis, evaluation, choice of materials and installation performed by your fitter.

Each automated system is unique, therefore, and only your fitter has the experience and professionalism required to create a system that is tailor-made to your requirements, featuring long-term safety and reliability, and, above all, professionally installed and compliant with current regulations.

An automated system is handy to have as well as being a valid security system. Just a few, simple operations are required to ensure it lasts for years.

Even if your automated system satisfies regulatory safety standards, this does not eliminate "residue risks", that is, the possibility of dangerous situations being generated, usually due to irresponsible and/or incorrect use. For this reason we would like to give you some suggestions on how to avoid these risks:

- **Before using the system for the first time:** ask your fitter to explain how residue risks can arise and read the instructions and warnings in the user handbook that your fitter will have given you. Keep this manual for future use and, if you should ever sell your automated system, hand it over to the new owner.
- **Your automated system carries out your commands to the letter:** Irresponsible and/or incorrect use may cause it to become dangerous. Do not use the system if people, animals and/or objects enter its operating area.
- **IT IS NOT A TOY!** Make sure children do not play near the system and keep the remote control device out of their reach.
- **Faults:** If you notice any abnormal behaviour, disconnect the system from the power supply immediately and perform the manual release operation (see figure). Do not attempt to repair the door but call in your fitter: the system will operate manually as it did before installation.
- **Maintenance:** to ensure long life and totally safe operation, the system required routine maintenance, just like any other piece of machinery. Establish maintenance times together with your fitter. Tau recommends a frequency of 6 months for normal domestic installations but this may vary depending on the intensity of use (always every 3000 work cycles). It is strictly forbidden to use cleaning equipment, such as high pressure water cleaners, and/or spray the automatic system with jets of water in general.

N.B.: All controls, maintenance work and/or repairs may only be carried out by qualified personnel.

- Do not modify the plant or the relative programming and adjustment parameters: your fitter will see to that.

N.B. Final testing, routine maintenance and any repairs must be documented by the fitter (in the relative spaces) and such documents kept by the owner of the system **(IF THE DOCUMENTS ARE NOT PRODUCED, THE WARRANTY WILL EXPIRE)**.

- **Disposal:** At the end of system life, make sure that it is demolished by qualified personnel and that the materials are recycled or disposed of according to local regulations.

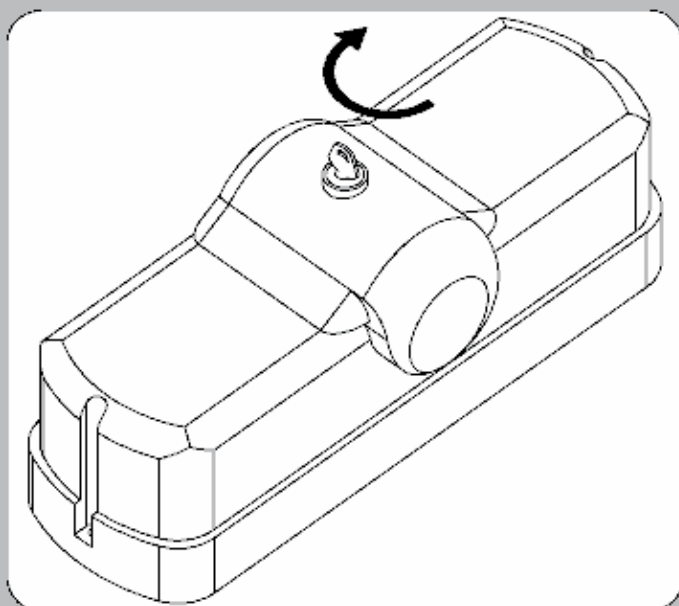

Fit the key into the cover of the release device and turn it clockwise.

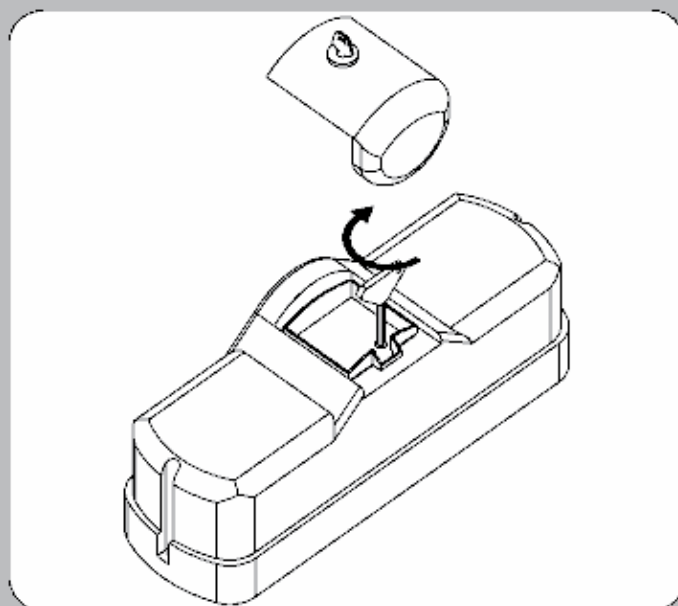

Fit the Allen key and turn it clockwise. Do not force the Allen key but move the leaf door at the same time to make sure it has been released.

The manual manoeuvre must only be performed with the automation inactive and AFTER having switched off the power from the mains.

N.B.: if your remote control unit (if supplied) starts working badly after a time, or does not work at all, the batteries may be flat (they can last from several months to 2/3 years depending on what type is used). This can be seen from the fact that the transmission confirmation LED gets dimmer or only turns on for brief moments. Before contacting your fitter, try exchanging the battery with one from a good transmitter: if this is the reason for the fault, simply replace the battery with another one of the same type.

If you wish to add a new automated system to your house, contact your fitter and we at Tau to have the advice of a specialist, the most developed products on the market, best operation and maximum automation compatibility.

Thank you for reading these suggestions and we trust you are fully satisfied with your new system: please contact your fitter for any further requirements.

PROGRAMMED MAINTANENCE SCHEDULE: Six-Monthly

Item:	Connection and Efficiency of Safety Breaker	Setting and correct operation of electronic clutch	Connection and operation of safety devices	Connection and efficiency of Earth Socket
Date of Service				

The TAU Guarantee: General Conditions

TAU guarantees this product shall be free from defect in manufacture for a period of 12 months from the date of invoice.

Should any fault occur within that period as a result of faulty workmanship or materials, TAU will make all necessary repairs, or at its discretion replace the product at no charge to the Customer except for freight. The appropriate Serial Number and Invoice Number must be quoted for all warranty claims.

All goods must be returned to Gate Drive Solutions Ltd, the New Zealand representative for TAU Automation Systems and associated TAU product for inspection or testing to assess if a claim is justified.

It is the responsibility and at the cost of the Customer, to return the goods for inspection and freight costs are the responsibility of the Customer.

For visits to the Customer's facilities, also during the guarantee period, a "Call-out fee" will be charged for travelling expenses and labour cost.

The guarantee is negated and will not apply in the following circumstances:-

- If a professional installer does not carry out the installation of the product in accordance with the instructions listed in this Installation and/or Maintenance Manual.
- If the product is not used and maintained in accordance with instructions or recommendations listed in this Installation and Maintenance Manual.
- If the product has been used in a manner beyond its design parameters.
- If original TAU spare parts were not used to install the product.
- If loss or damage caused by an Act of God, tampering, overvoltage, incorrect power supply, improper repairs, incorrect installation, or any other cause not within TAU the manufacturer's control.
- If a professional installer does not carry out routine maintenance operations according to the instructions or recommendations listed in this Installation and/or Maintenance Manual.
- If the product is tampered with or repaired by personnel not authorised to do so.
- If loss or damage is caused by rough treatment.
- Wear of components

The repair or replacement of goods under guarantee does not extend the guarantee period.

Goods returned under warranty for repair or testing will incur a charge to be fixed by Gate Drive Solutions Ltd if no fault is found.

Imported and marketed in New Zealand by GATE DRIVE SOLUTIONS LTD.

www.gatedrivesolutions.co.nz brian@gatedrivesolutions.co.nz

Phone: 09 419 5483 Mobile: 0274 907 192

The information contained in this document is subject to change without notice. June 2017